

Manual de utilizare

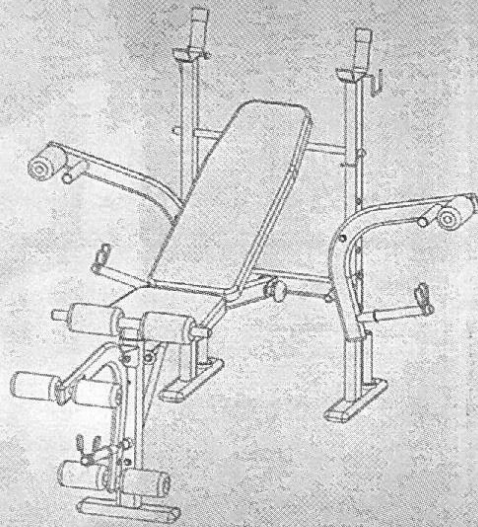

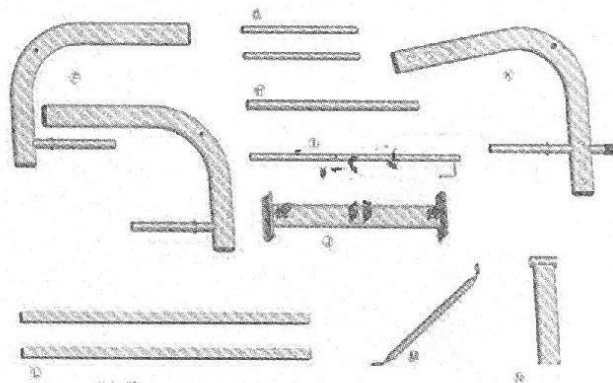

Pasul 6
Montati sezutul (B) pe bara (D) si securizati-l cu setul de suruburi (9).

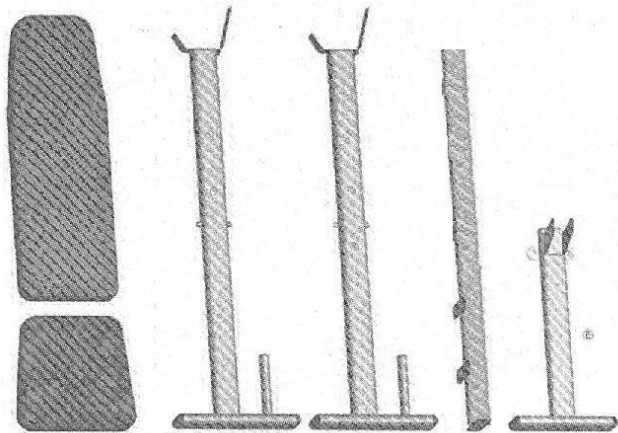

Pasul 7
Introduceti bara pentru reglare inclinatii spatari (I) in pozitia dorita, in una din cele 3 gauri de pe suportii de halterea (C).



Pasul 8
Montati barele (L) pe spatarul (A) si securizati-le cu setul de suruburi (8). Dupa care securizati spatarul (A) cu barele montate (L) pe bara (D) si securizati-l cu setul de suruburi (10).

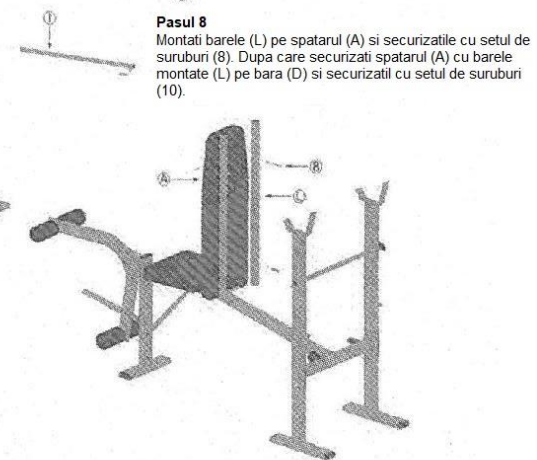

Pasul 9

Montati cele doua sigurante pentru pentru bara de haltera (U) in gaurile de pe suportii de haltera (C).

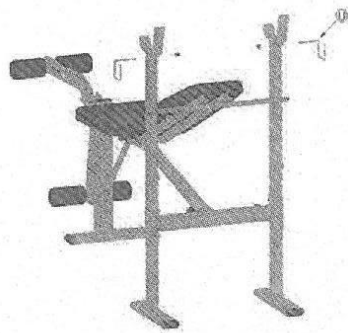

Pasul 10

Introduceti suportul (N) in piciorul (E) si securizati cu cuiul (W). Dupa care introduceti bara (H) in gaura din suportul (N) si introduceti buretii (P) pe bara (H).

