



MANUAL DE UTILIZARE

Aparat Tracțiuni Helcometru Sportmann DGZ-1907



Instructiuni de asamblare

PAS 1: Gasiti cadrul principal si atasati-i cadrul de baza.

1



2



PAS 2: Instalati suportul de scripeti, apoi bara verticala.

3



4



PAS 3: Inserati tampoanele cauciucate pe tijele de ghidare. Asezati tijele de ghidare in pozitia afisata in desenul de mai jos.

5

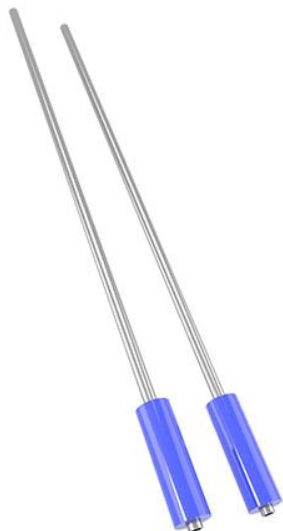

6

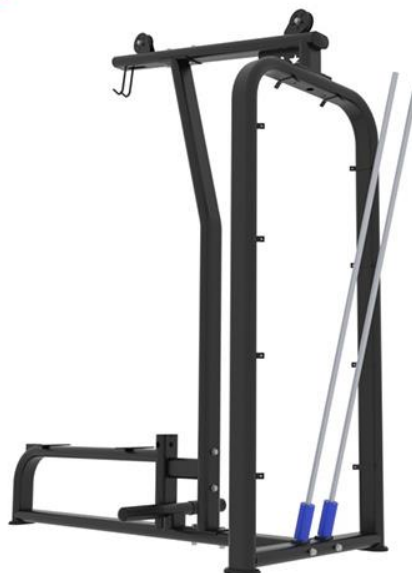

PAS 4: Inserati placile de greutate de sus in jos. La final, inserati si placa superioara.

7



8



PAS 5: Inserati placa de fixare si atasati-o cu suruburi in partea superioara a cadrului.

9



10



PAS 6: Instalati cablurile de otel si scripetii.

11



12



PAS 7: Atasati captuseala scaunului si rolele pentru picioare.

13



14



PAS 8: Atasati scutul posterior si scutul anterior al cadrului principal.

15



16



Metoda pentru distingerea orientarii placilor de greutate



Pasii pentru instalarea stivelor de greutate

PAS 1: Instalati prima placa de greutate de sus in jos.

1



PAS 2: Fiecare pas ulterior de montare a placilor este identic cu cel initial.

2



PAS 3: Greutatea unei placi este de 5 kg, cu o contragreutate implicita de 70 kg. Cantitatea este 13+1 (la inceput).

3



PAS 4: Instalati placa superioara cu tampoanele cauciucate.

4



PAS 5: Instalati placa de fixare, mutati-o in pozitia reprezentata in diagrama si apoi strangeti-o cu suruburi.

5

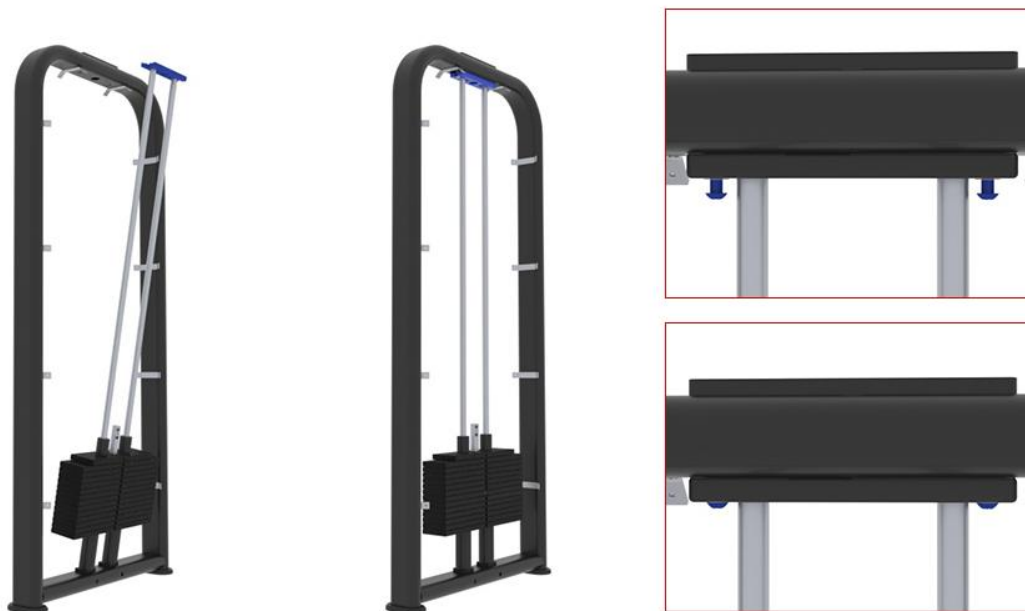

PAS 6: Instalarea cablurilor de oțel



Șuruburile de la fiecare conexiune a cablului de oțel trebuie strânse.



Felicitari! Ati finalizat asamblarea!





Distribuito:

SC SPORT BRANDS DISTRIBUTION SRL

Str. Depozitelor nr.21, Deva, jud. Hunedoara

Tel: +40377 101 448, email:comenzi@sport mag.ro

web: www.sport-mag.ro